

# LED DOWN LIGHT

## Product Manual

LETGO WALL WASHER

### To dear users

※ Thank you for choosing this quality LED Down Light.

※ To ensure correct function and safety, please read and follow all instructions carefully before assembly, installation and use of this luminaire. Please refer to these instructions for future reference.

### Attention:

Ensure that power is off on the main panel before starting installation.

※ Always ensure the power is OFF and the luminaire has cooled down before performing any maintenance, cleaning or making any adjustment to the luminaire.

※ Remove all packaging material from the product and be careful not to throw away accessories that may be hidden within the packaging material.

※ Check whether the luminaire has been damaged during transport. Do not operate/install any product which appears damaged in any way. Return the complete product to the place of purchase for inspection, repair or replacement.

※ This LED Down Light is not suitable for covering with thermal insulating materials. More details, please refer to below Clearance Information.

※ Failure to comply with the instructions in this manual may increase the risk of damage or injury and will void warranty.

Installation or maintenance should be operated by qualified electricians.

※ Use static free gloves when installation and maintenance of cleaning the luminaire to avoid markings.

※ Wiring: For luminaires with 0-10V dimming, or digital dimming, wires in different colors leads to appropriate control wires.

### Cut-out Size Sheet

Model	Cut hole size(tolerance)	Ceiling thickness	Cut-out
SD043068R	0-1mm	8~15mm	Φ68mm
SD043075R	0-2mm	8~15mm	Φ75mm
SD043068RL	0-7mm	8~20mm	Φ68mm

### Trim Version - Split Installation

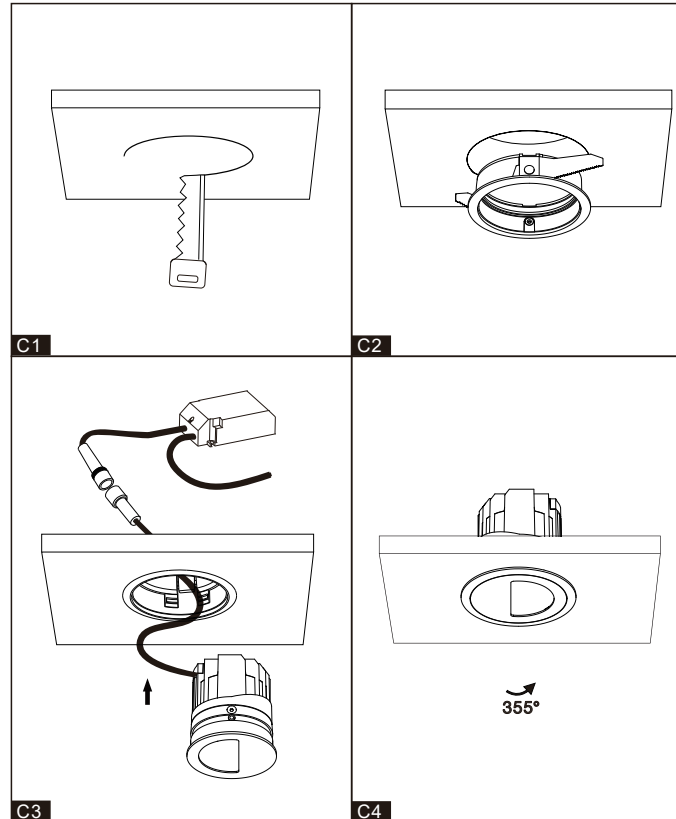

**Step 1:**  
Cut ceiling hole in proper size in the ceiling as per required cut-out size and shape. Hole size refer to above sheet. Ensure that there is nothing in the ceiling to obstruct the installation.(Fig. C1).

**Step 2:**  
Take out the bezel frame from luminaire, compress retainer clips/spring and install the frame into the cut hole. (Fig. C2).

**Step 3:**  
Connect power supply to power lead and pass the power supply through the ceiling opening. (Fig. C3).

**Step 4:**  
Put and lock the optical accessories in the frame body, if necessary or available. Combine the LED Engine with frame body by screwing in. Insert and push up the LED Module and frame body into the trim frame and secure it. (Fig. C3).

**Step 5:**  
Installation complete. (Fig. C4).

### Trimless Version - Split Installation

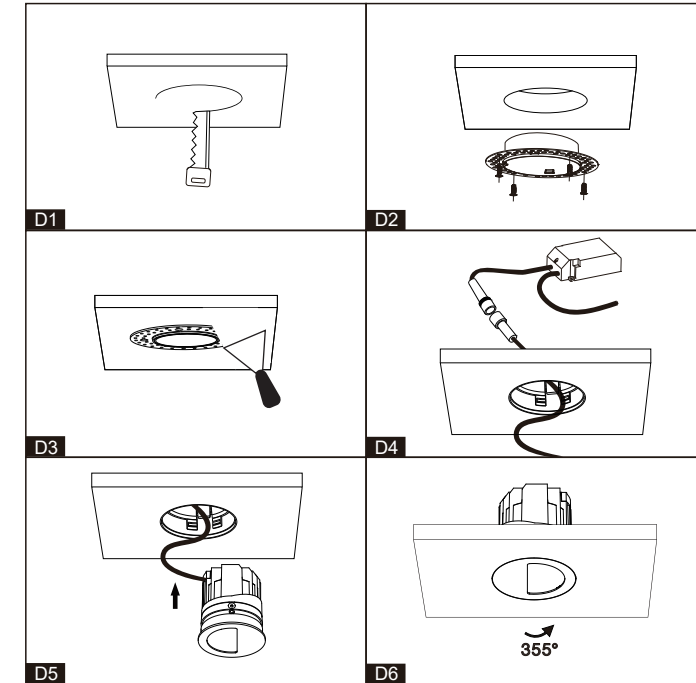

**Step 1:**  
Cut ceiling hole in proper size in the ceiling as per required cut-out size and shape. Hole size refer to above sheet. Ensure that there is nothing in the ceiling to obstruct the installation.(Fig. D1).

**Step 2:**  
Take out the trimless frame from the luminaire and insert it in ceiling cut hole. For maximum adhesion a bead of plaster/compound can be applied to ceiling before placing the trimless frame into position. Fasten to ceiling with screws. (Fig. D2).

**Step 3:**  
Starting outside edge, apply plaster/compound to trimless frame. Continue to apply until lip of trimless frame is covered. Allow plaster/compound to dry. Sand back the plaster until the surface is smooth. Repaint the ceiling as required. (Fig. D3).

**Step 4:**  
Put and lock the optical accessories in the frame body, if necessary or available. Combine the LED Engine with frame body by screwing in. Insert and push up the LED Module and frame body into the trim frame and secure it. (Fig. D4&D5).

**Step 5:**  
Installation complete. (Fig. D6).